

**BASCO®
PIPELINE
AFTERCoolERS**



API Heat Transfer

...world leaders in heat transfer technology

Basco PLAC for Compressed Air Cooling

Quality, Value and Performance.

An API Heat Transfer Tradition.

API has over 50 years of experience designing & building heat exchangers for all types of applications all over the world.

Whenever there is a need for cooling compressed air or gas in your piping system, consider the Basco® Pipeline Aftercooler.

Basco Pipeline Aftercoolers (PLAC)

The Basco **PLAC** and **PLAC II** aftercooler and companion separator provide an ideal combination to remove troublesome moisture from your compressed air or gas. Successful installations of Basco aftercoolers/separators worldwide provide conclusive proof of their effective performance in maintaining trouble-free operation of air powered tools and equipment.

The **PLAC** design has tubes effectively arranged to maximize heat transfer and reduce cooling water usage. Tubes are readily accessible for cleaning to maintain their high heat transfer efficiency and low pressure drop. Removable tube bundles allow cleaning of shell side surfaces. Fabricated according to ASME code, **PLAC's** are designed to operate at 150 psi maximum both sides.

Where space limitations for lengths and diameters exist, the Basco standard **PLAC II** unit is a compact version of the **PLAC**. It utilizes specially contoured BASCOR 3/8" or 5/8" tubes with enhanced surface for improved heat transfer.

The matching in-line cast iron centrifugal separator has been individually designed and sized for each aftercooler to provide maximum efficiency in removing virtually all moisture over the entire operating range of the aftercooler. All Basco separators are designed to bolt directly to the aftercooler, without the need for spools, to minimize pressure drop & overall unit length.

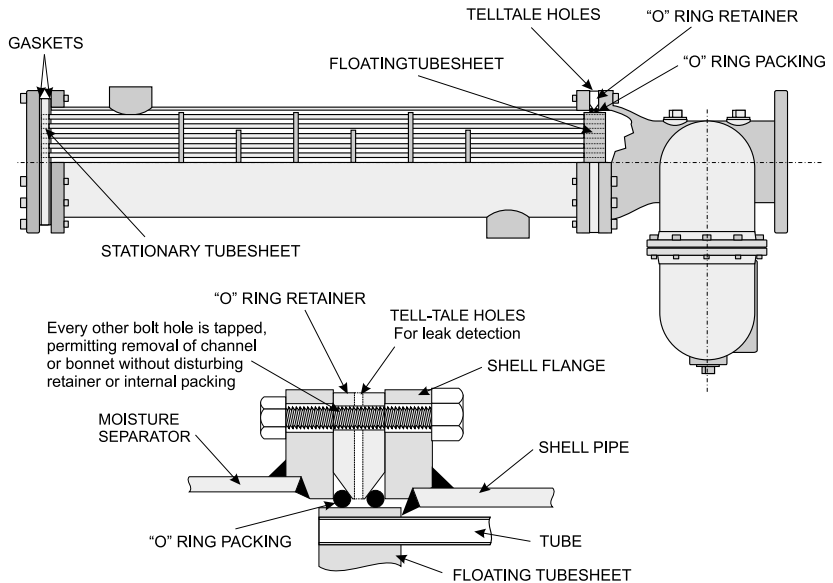

Features

Benefits

Removable Tube Bundle	<i>Simplifies cleaning of both tubes and shell sides, and reduces future maintenance costs.</i>
Double Packed Floating Tubesheet with O-Rings	<i>Allows for proper thermal expansion caused by temperature differences.</i>
Tell-Tale Holes	<i>Allows easy visual detection of leaks</i>
Shell Sizes from 6" to 16" without spools - separator bolts direct to unit.	<i>Meets virtually all in-line aftercooler requirements & conserves on space.</i>
Standard Pressure Range is 75 to 150 psi.*	<i>Standard design meets the majority of material & code requirements.</i>

*Higher pressures are available with a variety of material substitutions.

Basco Centrifugal Separator

Designed for installation with the Basco **PLAC** aftercooler or for retro fit with other suitable aftercooler units.

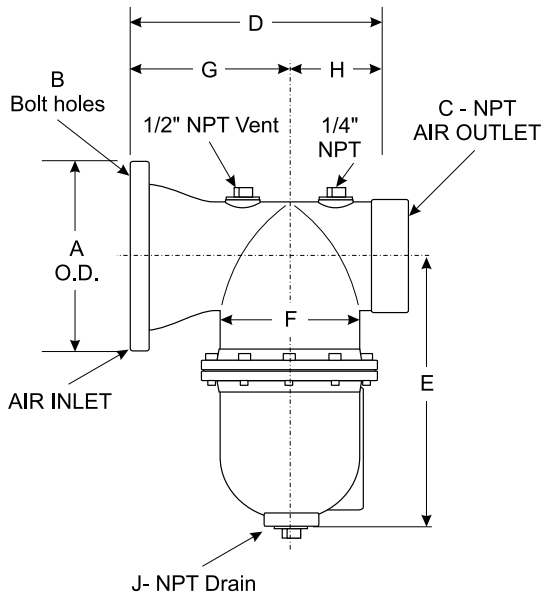

SIZES: 3 x 2 THRU 5 x 3

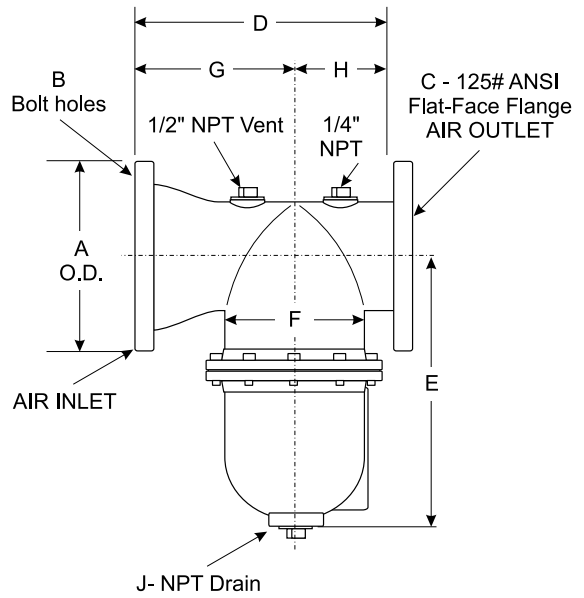

SIZES: 6 x 4 THRU 12 x 8

NOTE: 14x10 & 16x12 not shown

In/Out Size (in.)	Inlet A	N#	B-Bolt holes		Outlet C	D	E	F	G	H	J	Wgt. Lbs.
			Size	B.C								
3x2	6 ³ / ₈ "	8	5 ⁵ / ₈ "	5 ¹ / ₄ "	2" NPT	9 ¹ / ₄ "	11 ³ / ₄ "	5 ⁷ / ₈ "	5 ³ / ₈ "	3 ⁷ / ₈ "	1"	65
4x2¹/₂	7 ³ / ₈ "	8	5 ⁵ / ₈ "	6 ¹ / ₄ "	2 ¹ / ₂ " NPT	10 ¹ / ₄ "	13"	6 ⁵ / ₈ "	5 ³ / ₄ "	4 ¹ / ₂ "	1"	75
5x3	8 ¹ / ₂ "	12	5 ⁵ / ₈ "	7 ³ / ₈ "	3" NPT	11 ³ / ₄ "	14 ¹ / ₂ "	7 ³ / ₄ "	6 ³ / ₄ "	5"	1"	115
6x4	9 ¹ / ₂ "	12	5 ⁵ / ₈ "	8 ³ / ₈ "	4" 125#	15"	16 ¹ / ₄ "	9 ¹ / ₈ "	8 ¹ / ₂ "	6 ¹ / ₂ "	1 ¹ / ₄ "	160
8x6	11 ¹ / ₂ "	12	5 ⁵ / ₈ "	10 ³ / ₈ "	6" 125#	17 ¹ / ₂ "	19 ¹ / ₂ "	11 ¹ / ₄ "	9 ¹ / ₂ "	8"	1 ¹ / ₄ "	240
10x6	13 ³ / ₄ "	16	5 ⁵ / ₈ "	12 ⁵ / ₈ "	6" 125#	21"	24 ³ / ₄ "	13 ⁵ / ₈ "	11 ³ / ₄ "	9 ¹ / ₄ "	1 ¹ / ₂ "	330
12x8	15 ³ / ₄ "	16	5 ⁵ / ₈ "	14 ⁵ / ₈ "	8" 125#	26"	30"	16"	14"	12"	1 ¹ / ₂ "	510
14x10	17"	20	5 ⁵ / ₈ "	15 ⁷ / ₈ "	10" 125#	30"	37"	18"	15"	15"	2"	610
16x12	19"	20	5 ⁵ / ₈ "	17 ⁷ / ₈ "	12" 125#	38"	55"	24"	19"	19"	2"	935

Design - 150 P.S.I.G. @ 400°F. Consult factory for other designs.

Optional Separators & Traps Available

Alternative separators and traps are available from stock in 1-1/4" NPT to 4" NPT or flange sizes for both removable and fixed bundle aftercoolers.

TC Trap



Type "T" Separator



Type "TC" Separator includes integral trap



Capacity Ratings of PLAC

The BASCO standard **PLAC** unit is designed with a removable tube bundle with either 3/8" or 5/8" tubes. Fabricated according to ASME code,

they are designed to operate at 150 psi maximum. Units for operation up to 300 psi are available for specialized applications. For further infor-

mation please contact your nearby API Heat Transfer Representative or the factory.

Application	Single Stage		Single Stage		Two Stage		Rotary		Multi-Stage		Multi-Stage		Multi-Stage	
Present Range	50 PSI		70-125 PSI		80-125 PSI		80-125 PSI		200 PSI		250 PSI		300 PSI	
Approach T Aftercooler Model	15°	10°	15°	10°	15°	10°	15°	10°	15°	10°	15°	10°	15°	10°
3BR03072	170	100	130	80	220	130	240	120	190	120	180	120	170	110
3BR04072	380	220	300	180	500	280	550	270	430	280	410	260	380	250
3BR05072	680	390	540	320	890	510	990	480	780	500	730	470	680	440
3BR06072	1180	670	920	540	1560	870	1730	830	1350	860	1270	810	1180	760
3BR08072	2270	1300	1780	1050	3000	1680	3340	1610	2600	1650	2440	1560	2270	1460
3BR10072	3890	2230	3050	1790	5130	2880	5710	2750	4450	2830	4180	2670	3890	2500
3BR12072	5930	3410	4650	2740	7830	4390	8720	4200	6800	4320	6370	4070	5940	3810
3BR14072	7370	4230	5780	3400	9720	5450	10830	5220	8440	5370	7920	5060	7380	4740
3BR16072	9930	5710	7800	4590	13120	7360	14610	7040	11390	7240	10680	6830	9960	6390
5BR03129	180	100	140	80	230	130	260	120	200	130	190	120	180	110
5BR04129	340	190	260	150	450	250	500	240	390	240	360	230	340	210
5BR05129	510	290	400	230	670	380	750	360	580	370	550	350	510	330
5BR06129	1090	610	850	490	1450	800	1620	760	1250	780	1170	740	1080	690
5BR08129	1990	1120	1550	900	2660	1460	2980	1390	2300	1440	2150	1350	2000	1260
5BR10129	3320	1870	2590	1500	4430	2440	4960	2330	3830	2400	3580	2250	3330	2110
5BR12129	5200	2940	4050	2350	6940	3820	7760	3640	6000	3750	5610	3530	5220	3300
5BR14129	6470	3650	5040	2920	8640	4750	9660	4530	7460	4670	6980	4390	6490	4100
5BR16129	8650	4880	6730	3900	11540	6340	12900	6060	9970	6240	9330	5870	8680	5490

Ratings in SCFM @ 14.7 PSIA & 60°F

NOTES

Above capacities are based upon the following average conditions:

- A) Cooling water inlet = 75° F,
Temperature rise = 20° F
- B) Tabulated capacities allow for condensing water vapor heat load. Initial suction conditions of 14.5 psi., 70° F and 60% relative humidity are assumed.
- C) Average air stream pressure drop (aftercooler and separator) will equal 2%-3% of line pressure.
- D) Inlet air temperature:
Single stage (50 psi) = 325° F
Single stage (70-125 psi) = 350° F
Two stage (80-125 psi) = 250° F
Rotary (80-125 psi) = 170° F
Multi-stage (200 psi)* = 300° F
Multi-stage (250 psi)* = 310° F
Multi-stage (300 psi)* = 325° F

*Non-standard designs

Standard Design Data

	Shell	Tube
Exchanger		
Design Pressure (PSI)	150	150
Design Temperature (°F) Max/Min	300/20	400/20
Separator		
Design Pressure (PSI)	150	150
Design Temperature (°F) Max/Min	300/20	400/20

Description

Plac/Pipeline Aftercooler

3BR = 3/8" OD Bare Tube; Removable Bundle
5BR = 5/8" OD Bare Tube; Removable Bundle

PLAC 150# Pipeline Aftercooler

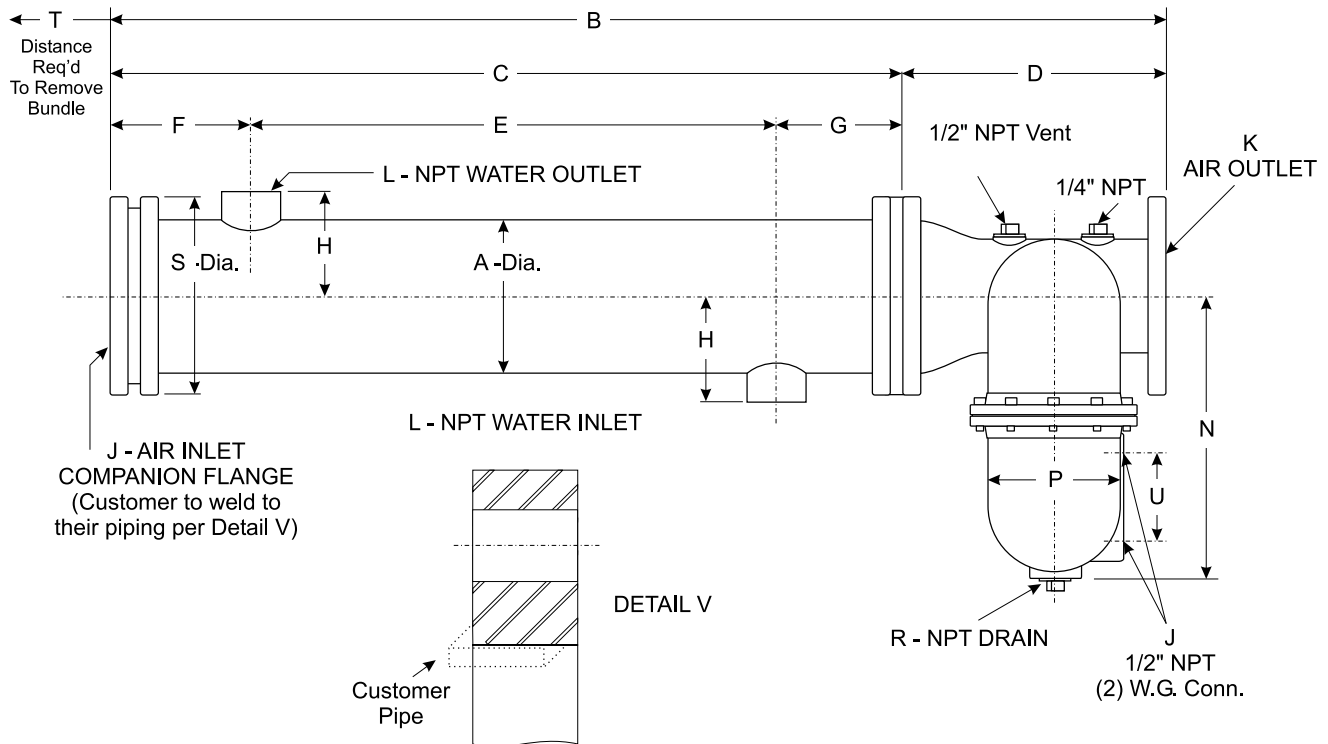

PLAC 3/8" O.D., x 6'0" Lg. Tubes/ASME Code Construction

Unit Size	A	B	C	D	E	F	G	H	J	K	L	N	P	R	S	T	U	Wgt. Lbs.
3	3 1/2"	6' 10"	6 3/4"	9 1/4"	5' 3"	5 3/16"	4 9/16"	2 5/8"	3 5/8"	2" NPT	1"	11 3/4"	5 7/8"	1"	6 3/8"	6' 6"	4 3/4"	120
4	4 1/2"	6' 11 1/16"	6 13/16"	10 1/4"	5' 3"	5 1/4"	4 9/16"	3 1/4"	4 5/8"	2 1/2" NPT	1"	13"	6 5/8"	1"	7 3/8"	6' 6"	4 3/4"	180
5	5 9/16"	7 9/16"	6 13/16"	11 3/4"	5' 3"	5 1/4"	4 9/16"	3 7/8"	5 11/16"	3" NPT	1 1/4"	14 1/2"	7 3/4"	1"	8 1/2"	6' 6"	4 3/4"	250
6	6 5/8"	7' 3 3/4"	6 3/4"	15"	5' 3"	5 3/16"	4 9/16"	4 7/16"	6 3/4"	4" 125# FF	1 1/4"	16 1/4"	9 1/8"	1 1/4"	9 1/2"	6' 6"	4 3/4"	340
8	8 5/8"	7' 6 3/8"	6 7/8"	17 1/2"	5' 3"	5 5/16"	4 9/16"	5 11/16"	8 3/4"	6" 125# FF	1 1/2"	19 1/2"	11 1/4"	1 1/4"	11 1/2"	6' 6"	4 3/4"	600
10	10 3/4"	7' 9 7/8"	6 7/8"	21"	5' 2"	5 13/16"	5 1/16"	6 7/8"	10 7/8"	6" 125# FF	2"	24 3/4"	13 5/8"	1 1/2"	13 3/4"	6' 6"	6"	840
12	12 3/4"	8' 3"	6' 1"	26"	5' 1"	6 7/16"	5 9/16"	8 1/8"	12 7/8"	8" 125# FF	3"	30"	16"	1 1/2"	15 3/4"	6' 6"	6"	1190
14	14"	8' 7 1/16"	6' 1 1/16"	30"	5' 0"	7"	6 1/16"	8 3/4"	14 1/8"	10" 150# RF	3"	37"	18"	2"	17"	6' 6"	7 7/8"	1400
16	16"	9' 3 1/4"	6' 1 1/4"	38"	5' 0"	7 1/4"	6"	9 7/8"	16 1/8"	12" 150# RF	3"	55"	24"	2"	19"	6' 6"	7 7/8"	2075

PLAC 5/8" O.D., x 10'9" Lg. Tubes

Unit Size	A	B	C	D	E	F	G	H	J	K	L	N	P	R	S	T	U	Wgt. Lbs.
3	3 1/2"	11' 7"	10' 9 3/4"	9 1/4"	10'	5 3/16"	4 9/16"	2 5/8"	3 5/8"	2" NPT	1"	11 3/4"	5 7/8"	1"	6 3/8"	11' 3"	4 3/4"	160
4	4 1/2"	11' 8 1/16"	10' 9 13/16"	10 1/4"	10'	5 1/4"	4 9/16"	3 1/4"	4 5/8"	2 1/2" NPT	1"	13"	6 5/8"	1"	7 3/8"	11' 3"	4 3/4"	260
5	5 9/16"	11' 9 9/16"	10' 9 13/16"	11 3/4"	10'	5 1/4"	4 9/16"	3 7/8"	5 11/16"	3" NPT	1 1/4"	14 1/2"	7 3/4"	1"	8 1/2"	11' 3"	4 3/4"	360
6	6 5/8"	12 3/4"	10' 9 3/4"	15"	10'	5 3/16"	4 9/16"	4 7/16"	6 3/4"	4" 125# FF	1 1/4"	16 1/4"	9 1/8"	1 1/4"	9 1/2"	11' 3"	4 3/4"	480
8	8 5/8"	12' 3 3/8"	10' 9 7/8"	17 1/2"	10'	5 5/16"	4 9/16"	5 11/16"	8 3/4"	6" 125# FF	1 1/2"	19 1/2"	11 1/4"	1 1/4"	11 1/2"	11' 3"	4 3/4"	890
10	10 3/4"	12' 6 7/8"	10' 9 7/8"	21"	9' 11"	5 13/16"	5 1/16"	6 7/8"	10 7/8"	6" 125# FF	2"	24 3/4"	13 5/8"	1 1/2"	13 3/4"	11' 3"	6"	1245
12	12 3/4"	13' 0"	10' 10"	26"	9' 10"	6 7/16"	5 9/16"	8 1/8"	12 7/8"	8" 125# FF	3"	30"	16"	1 1/2"	15 3/4"	11' 3"	6"	1760
14	14"	13' 4 1/16"	10' 10 1/16"	30"	9' 9"	7"	6 1/16"	8 3/4"	14 1/8"	10" 150# RF	3"	37"	18"	2"	17"	11' 3"	7 7/8"	2160
16	16"	14 1/4"	10' 10 1/4"	38"	9' 9"	7 1/4"	6"	9 7/8"	16 1/8"	12" 150# RF	3"	55"	24"	2"	19"	11' 3"	7 7/8"	2985

Use only certified drawings for construction.

Capacity Ratings of PLAC II

The BASCO standard **PLAC II** unit is a compact version of the PLAC. It utilizes specially contoured BASCOR® 3/8" or 5/8" tubes with enhanced surface. Fabricated ac-

ording to ASME code, they are designed to operate at 150 psi maximum. Units for operation up to 300 psi* are available for specialized applications. For further information

please contact your nearby API Heat Transfer Representative or the factory.

Application Present Range Approach T Aftercooler Model	Single Stage 50 PSI		Single Stage 70-125 PSI		Two Stage 80-125 PSI		Rotary 80-125 PSI		Multi-Stage 200 PSI		Multi-Stage 250 PSI		Multi-Stage 300 PSI	
	15°	10°	15°	10°	15°	10°	15°	10°	15°	10°	15°	10°	15°	10°
	3CR03036	170	100	130	80	220	130	240	120	190	120	180	120	170
3CR04036	380	220	300	180	500	280	550	270	430	280	410	260	380	250
3BR05036	680	390	540	320	890	510	990	480	780	500	730	470	680	440
3CR06036	1180	670	920	540	1560	870	1730	830	1350	860	1270	810	1180	760
3CR08036	2270	1300	1780	1050	3000	1680	3340	1610	2600	1650	2440	1560	2270	1460
3CR10036	3890	2230	3050	1790	5130	2880	5710	2750	4450	2830	4180	2670	3890	2500
3CR12036	5930	3410	4650	2740	7830	4390	8720	4200	6800	4320	6370	4070	5940	3810
3CR14036	7370	4230	5780	3400	9720	5450	10830	5220	8440	5370	7920	5060	7380	4740
3CR16036	9930	5710	7800	4590	13120	7360	14610	7040	11390	7240	10680	6830	9960	6390
5CR03060	160	90	120	70	210	120	230	110	180	110	170	110	160	110
5CR04060	320	180	240	140	420	230	470	220	360	230	340	210	320	210
5CR05060	500	280	380	220	660	360	740	350	570	360	530	340	500	330
5CR06060	810	460	630	370	1080	590	1210	570	930	580	870	550	810	510
5CR08060	1620	910	1260	730	2160	1190	2410	1130	1870	1170	1750	1100	1620	1030
5CR10060	2660	1500	2060	1200	3540	1950	3960	1860	3060	1920	2860	1800	2660	1690
5CR12060	4140	2330	3220	1870	5520	3040	6170	2900	4770	2990	4460	2810	4150	2630
5CR14060	5220	2940	4060	2350	6960	3830	7780	3650	6010	3770	5620	3540	5230	3310
5CR16060	6980	3930	5420	3140	9300	5120	10400	4880	8040	5030	7510	4730	6990	4430

Ratings in SCFM @ 14.7 PSIA & 60°F

NOTES

Above capacities are based upon the following average conditions:

- A) Cooling water inlet = 75° F,
Temperature rise = 20° F
- B) Tabulated capacities allow for condensing water vapor heat load. Initial suction conditions of 14.5 psi., 70° F and 60% relative humidity are assumed.
- C) Average air stream pressure drop (aftercooler and separator) will equal 2%-3% of line pressure.
- D) Inlet air temperature:
Single stage (50 psi) = 325° F
Single stage (70-125 psi) = 350° F
Two stage (80-125 psi) = 250° F
Rotary (80-125 psi) = 170° F
Multi-stage (200 psi)* = 300° F
Multi-stage (250 psi)* = 310° F
Multi-stage (300 psi)* = 325° F

*Non-standard designs

Standard Design Data

	Shell	Tube
Exchanger		
Design Pressure (PSI)	150	150
Design Temperature (°F) Max/Min	300/20	400/20
Separator		
Design Pressure (PSI)	150	150
Design Temperature (°F) Max/Min	300/20	400/20

Description

Plac/Pipeline Aftercooler
3CR = 3/8" OD Contoured Tubes; Removable Bundle
5CR = 5/8" OD Contoured Tubes; Removable Bundle

PLAC II 150# Pipeline Aftercooler

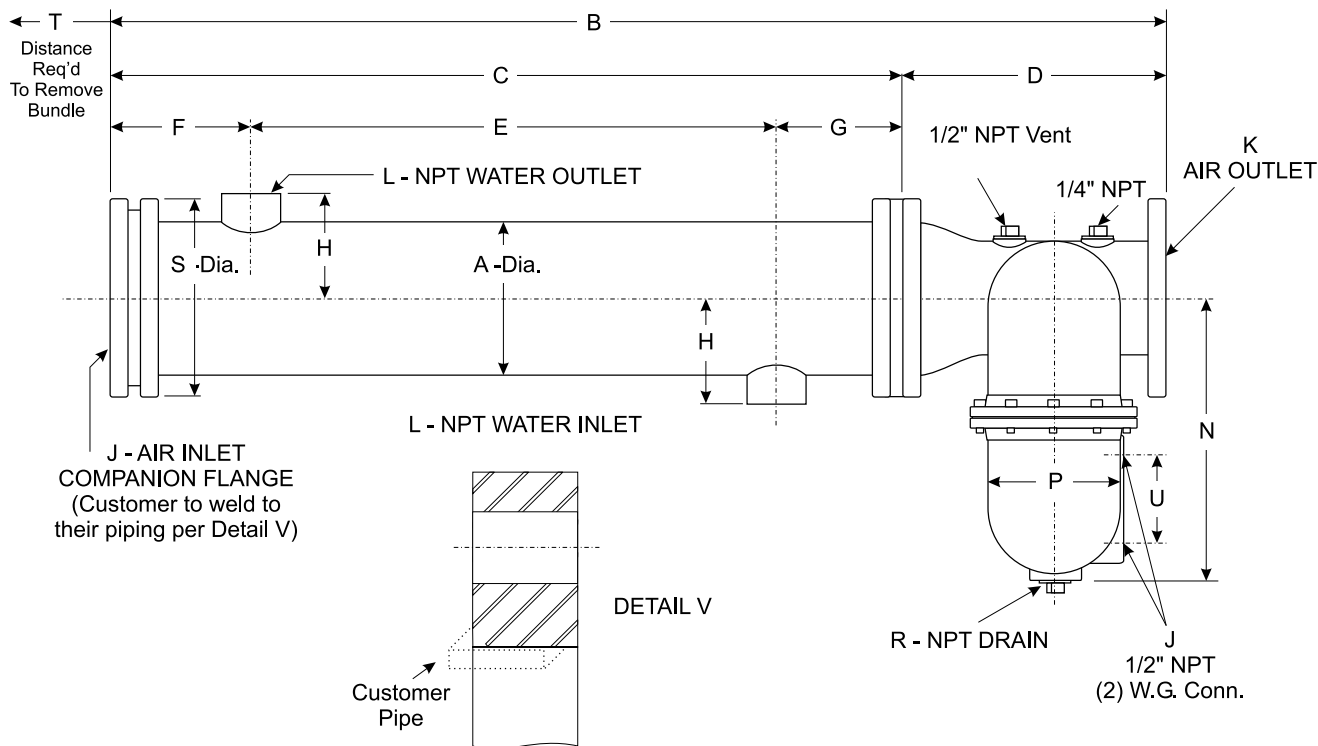

PLAC II 3/8" O.D., 3'0" Lg. Bascor® Tubes/ASME Code Construction

Unit Size	A	B	C	D	E	F	G	H	J	K	L	N	P	R	S	T	U	Wgt. Lbs.
3	3 1/2"	3' 10"	3 3/4"	9 1/4"	2' 3"	5 3/16"	4 9/16"	2 5/8"	3 5/8"	2" NPT	1"	11 3/4"	5 7/8"	1"	6 3/8"	3' 6"	4 3/4"	90
4	4 1/2"	3' 11 1/16"	3 13/16"	10 1/4"	2' 3"	5 1/4"	4 9/16"	3 1/4"	4 5/8"	2 1/2" NPT	1"	13"	6 5/8"	1"	7 3/8"	3' 6"	4 3/4"	135
5	5 9/16"	4' 9 1/16"	3 13/16"	11 3/4"	2' 3"	5 1/4"	4 9/16"	3 7/8"	5 11/16"	3" NPT	1 1/4"	14 1/2"	7 3/4"	1"	8 1/2"	3' 6"	4 3/4"	185
6	6 5/8"	4' 3 3/4"	3 3/4"	15"	2' 3"	5 3/16"	4 9/16"	4 7/16"	6 3/4"	4" 125# FF	1 1/4"	16 1/4"	9 1/8"	1 1/4"	9 1/2"	3' 6"	4 3/4"	250
8	8 5/8"	4' 6 3/8"	3 7/8"	17 1/2"	2' 3"	5 5/16"	4 9/16"	5 11/16"	8 3/4"	6" 125# FF	1 1/2"	19 1/2"	11 1/4"	1 1/4"	11 1/2"	3' 6"	4 3/4"	460
10	10 3/4"	4' 9 7/8"	3 7/8"	21"	2' 2"	5 13/16"	5 1/16"	6 7/8"	10 7/8"	6"-125# FF	2"	24 3/4"	13 5/8"	1 1/2"	13 3/4"	3' 6"	6"	630
12	12 3/4"	5' 3"	3' 1"	26"	2' 1"	6 7/16"	5 9/16"	8 1/8"	12 7/8"	8"-125# FF	3"	30"	16"	1 1/2"	15 3/4"	3' 6"	6"	900
14	14"	5' 7 7/16"	3' 1 1/16"	30"	2' 0"	7"	6 1/16"	8 3/4"	14 1/8"	10"-150# RF	3"	37"	18"	2"	17"	3' 6"	7 7/8"	1035
16	16"	6' 3 1/4"	3' 1 1/4"	38"	2' 0"	7 1/4"	6"	9 7/8"	16 1/8"	12"-150# RF	3"	55"	24"	2"	19"	3' 6"	7 7/8"	1620

PLAC II 5/8" O.D., 5'0" Lg. Bascor® Tubes

Unit Size	A	B	C	D	E	F	G	H	J	K	L	N	P	R	S	T	U	Wgt. Lbs.
3	3 1/2"	5'-10"	5 3/4"	9 1/4"	4' 3"	5 3/16"	4 9/16"	2 5/8"	3 5/8"	2" NPT	1"	11 3/4"	5 7/8"	1"	6 3/8"	5' 6"	4 3/4"	100
4	4 1/2"	5' 11 1/16"	5 13/16"	10 1/4"	4' 3"	5 1/4"	4 9/16"	3 1/4"	4 5/8"	2 1/2" NPT	1"	13"	6 5/8"	1"	7 3/8"	5' 6"	4 3/4"	165
5	5 9/16"	6' 9 1/16"	5 13/16"	11 3/4"	4' 3"	5 1/4"	4 9/16"	3 7/8"	5 11/16"	3" NPT	1 1/4"	14 1/2"	7 3/4"	1"	8 1/2"	5' 6"	4 3/4"	230
6	6 5/8"	6' 3 3/4"	5 3/4"	15"	4' 3"	5 3/16"	4 9/16"	4 7/16"	6 3/4"	4" 125# FF	1 1/4"	16 1/4"	9 1/8"	1 1/4"	9 1/2"	5' 6"	4 3/4"	295
8	8 5/8"	6' 6 3/8"	5 7/8"	17 1/2"	4' 3"	5 5/16"	4 9/16"	5 11/16"	8 3/4"	6" 125# FF	1 1/2"	19 1/2"	11 1/4"	1 1/4"	11 1/2"	5' 6"	4 3/4"	600
10	10 3/4"	6' 9 7/8"	5 7/8"	21"	4' 2"	5 13/16"	5 1/16"	6 7/8"	10 7/8"	6" 125# FF	2"	24 3/4"	13 5/8"	1 1/2"	13 3/4"	5' 6"	6"	815
12	12 3/4"	7' 3"	5' 1"	26"	4' 1"	6 7/16"	5 9/16"	8 1/8"	12 7/8"	8" 125# FF	3"	30"	16"	1 1/2"	15 3/4"	5' 6"	6"	1145
14	14"	7' 7 7/16"	5' 1 1/16"	30"	4'	7"	6 1/16"	8 3/4"	14 1/8"	10" 150# RF	3"	37"	18"	2"	17"	5' 6"	7 7/8"	1390
16	16"	8' 3 1/4"	5' 1 1/4"	38"	4'	7 1/4"	6"	9 7/8"	16 1/8"	12" 150# RF	3"	55"	24"	2"	19"	5' 6"	7 7/8"	2015

Use only certified drawings for construction.

API Heat Transfer

API Heat Transfer, Inc.
2777 Walden Avenue
Buffalo, NY 14225
(716) 684-6700

Divisions:

API Airtech ISO-9001 Certified

Air Cooled Aluminum Heat Exchangers

91 North Street • P.O. Box 68
Arcade, New York 14009-0068
(716) 496-5755 • Fax: (716) 496-5776

API Basco ISO-9001 Certified

Basco/Whitlock Shell & Tube Heat Exchangers

2777 Walden Avenue
Buffalo, New York 14225
(716) 684-6700 • Fax: (716) 684-2129

API Ketema

Acme® Refrigeration Equipment

2300 West Marshall Drive
Grand Prairie, Texas 75051
(972) 647-2626 • Fax: (972) 641-1518

API Schmidt-Bretten

*Plate Heat Exchangers and
Thermal Process Systems*

2777 Walden Avenue
Buffalo, New York 14225
(716) 684-6700 • Fax: (716) 684-2129

API Schmidt-Bretten GmbH.

ISO-9001 Certified

*Plate Heat Exchangers and
Thermal Process Systems*

P.O. Box 1580 D-75005 Bretten
Pforzheimer Strasse 46
D-75015 Bretten, Germany
7252/53-101 • Fax: 7252/53-201

**Call your local API Sales Representative or API
directly toll-free at 1-877-API HEAT.**

**Visit us at www.apiheattransfer.com or
e-mail us at sales@apiheattransfer.com**

Other Products Available from API Heat Transfer

Type 500 Shell and Tube Heat Exchangers



General purpose exchangers designed to cool oil, compressed air and other industrial fluids. A variety of constructions, port configurations and materials are available. ASME and TEMA-C available. Diameters from 3" (7.62 cm) to 12" (30.48 cm).

TEMA Shell and Tube



A wide variety of TEMA types are available using pre-engineered or custom designs in various sizes and materials. Shell diameters from 6" (15.24 cm) to 60" (152.4 cm), ASME, TEMA, API, ABS, TUV, ISPEL and other code constructions available.

Extended Surface



Unique, patented plate-fin design for centrifugal or axial compressor intercooler and aftercooler applications with minimal pressure loss. Design eliminates external separators. ASME code design is standard. Diameters from 20" (50.8 cm) to 120" (304.8 cm).

Plate Heat Exchangers



Compact units provide excellent heat transfer and small size. Plates are pressed from stainless steel, titanium and other alloys. Gaskets of nitrile, EPDM, Viton®, compressed fiber and Teflon® are used. Gasket-free welded and brazed designs available.

Refrigerant Evaporators & Condensers



Off-the-shelf, standard units reflect the latest in heat exchanger technology for maximum performance and low cost. Ideal for OEM or aftermarket applications. Numerous design and material options are available. Tonnage capacity ranges from 5 to over 400 tons.

Brazed Plate Heat Exchangers



Off-the-shelf, standard units reflect the latest in plate heat exchanger technology for maximum performance and low cost. Ideal for OEM or aftermarket applications. Many models stocked and ready to ship. Models for process or refrigeration applications.

Air-Cooled Heat Exchangers



High efficiency, brazed aluminum coolers for cooling a wide variety of liquids and gases with ambient air. Lightweight, yet rugged. Capable of cooling multiple fluids in single unit. Models can be supplied with cooling fan and a variety of drives.

ACME® Packaged Chillers



Packaged chillers, air and water cooled, with or without pumping systems ranging from 1/2 to over 400 tons. Electromechanical and PLC controls. Modular systems are available from stock.